

SL-135E (t=1.3) S=1/2

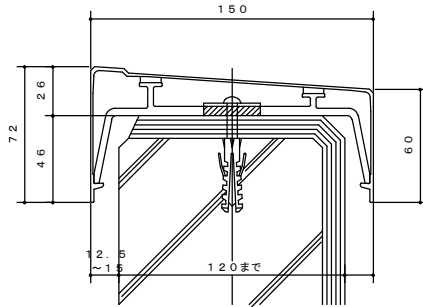

SL-150E (t=1.3) S=1/2

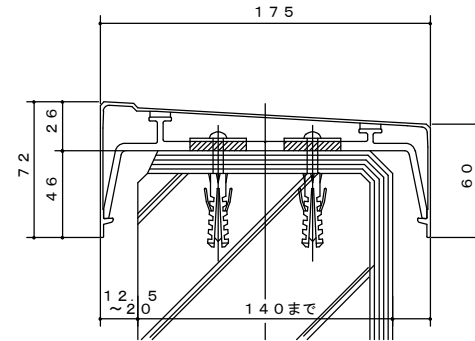

SL-175E (t=1.4) S=1/2
SL-175K (t=2.0) S=1/2

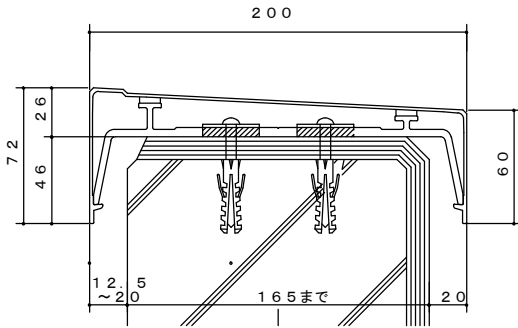

SL-200E (t=1.5) S=1/2
SL-200K (t=2.0) S=1/2

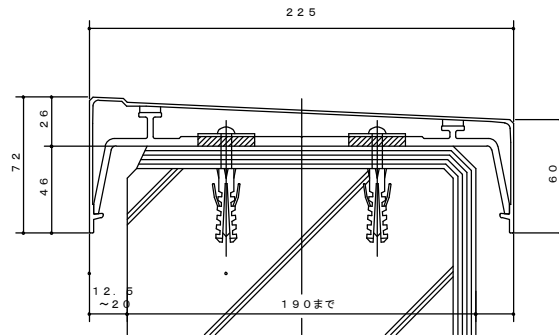

SL-225E (t=1.6) S=1/2
SL-225K (t=2.0) S=1/2

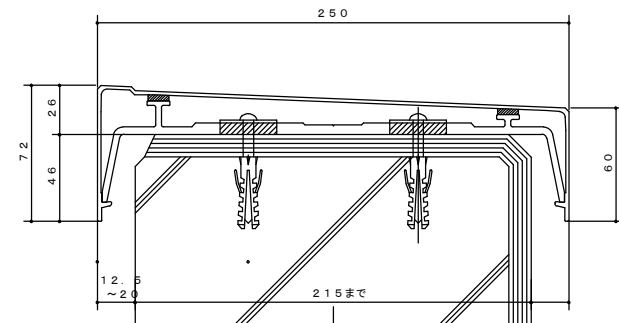

SL-250E (t=1.8) S=1/2
SL-250K (t=2.2) S=1/2