

基本断面詳細 H = 100 / 3000N / 1.0G

S = 1 : 3

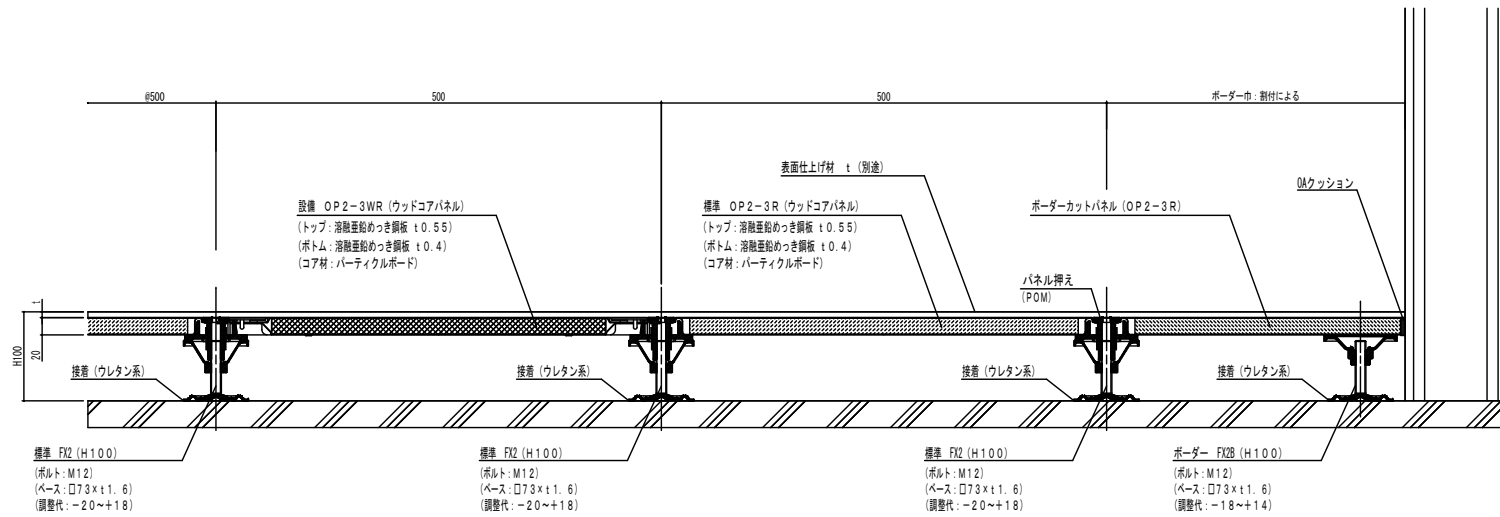

基本断面詳細 H = 100 / 5000N / 1.0G

S = 1 : 3

